

A Study on the Impact of Chamber Size, Configuration, Environmental Factors and Maximum Power Point Tracking (MPPT) Integration on Microbial Fuel Cell Voltage

Siti Kudnie Sahari^{1*}, Nashley Ursula Mundi Ujai¹, Thommy Thomas¹, Ibrahim Yakub¹, Marini Sawawi¹, Lilik Hasanah², Abdul Rahman Kram¹, Zaidi Embong³, Kasumawati Lias¹, Annie Joseph¹, Kho Lee Chin¹ and Sharifah Masniah Wan Masra¹

¹Faculty of Engineering, Universiti Malaysia Sarawak, 94300 Kota Samarahan, Sarawak, Malaysia

²Faculty of Mathematics and Sciences Education, Indonesia University of Education, Bandung, Jawa Barat 40154, Indonesia

³Faculty of Applied Science and Technology, Universiti Tun Hussein Onn Malaysia, 84600 Muar Johor, Malaysia

ABSTRACT

The study examines the effect of chamber size, Microbial Fuel Cell (MFC) arrangement, environmental conditions on voltage production, and the influence of connecting Power Management System (PMS) with MFC. A 6-unit single-chamber MFC device was built using soil as a catalyst and coconut leaves as a substrate. It was then connected to a PMS. The study showed that a 350

ml MFC unit arranged in series produced a greater voltage of 457 mV compared to a 700 ml container. The smaller chamber was connected in series and integrated with a PMS consisting of a charge pump, DC-DC boost converter, and Maximum Power Point Tracking (MPPT), which led to a maximum stable voltage of 10.56 V. It highlights the possibility of increasing voltage consistently by using smaller MFC chambers, dirt as a catalyst, coconut leaves as a substrate, and aluminum as an electrode, together with a thorough PMS setup.

Keywords: Boost converter, charge pump, microbial fuel cell, power management system, soil microbial fuel cell (SMFC), zinc

ARTICLE INFO

Article history:

Received: 30 March 2024

Accepted: 1 October 2024

Published: 21 February 2025

DOI: <https://doi.org/10.47836/pjst.33.2.04>

E-mail addresses:

sskudnie@unimas.my (Siti Kudnie Sahari)
nashleyujai@gmail.com (Nashley Ursula Mundi Ujai)
t5thommy@gmail.com (Thommy Thomas)
yibrahim@unimas.my (Ibrahim Yakub)
smarini@unimas.my (Marini Sawawi)
lilikhasanah@upi.edu (Lilik Hasanah)
karahman@unimas.my (Abdul Rahman Kram)
zembong@gmail.com (Zaidi Embong)
lkasumawati@unimas.my (Kasumawati Lias)
jannie@unimas.my (Annie Joseph)
lckho@unimas.my (Kho Lee Chin)
wmmasniah@unimas.my (Sharifah Masniah Wan Masra)

*Corresponding author

INTRODUCTION

The yearly rise in global electricity usage poses a significant environmental threat. The utilization of traditional fuel sources such as gas, coal and oil for power production has led to a rise in greenhouse gas (GHG) emissions, which in turn has contributed to the negative impacts of climate change (Chen et al., 2023). This alarming trend is worsened by the consumption of limited non-renewable resources and the rapid expansion of the energy sector's economy and industry. Numerous developing countries have extensively explored alternative and sustainable energy sources to adjust their strategic approaches to addressing the environmental challenges posed by traditional energy practices (Kabeyi & Olanrewaju, 2022).

Various renewable energy sources have been developed to meet the increasing need for energy. An emerging technology that is currently being developed is the MFCs. Employing MFC helps minimize the emission of dangerous chemicals, such as carbon dioxide and wastewater, produced by major companies, which can jeopardize human health and the ecosystem. MFC functions as a bio-electrochemical system, wherein organic chemicals undergo chemical reactions that are converted into electrical energy through the catalytic activities of bacteria within a biofilm (Santoro et al., 2017). The bacteria's end-product produces electrons, which move from an anode chamber (where oxidation occurs) to a cathode chamber (where reduction occurs) (Rabaey & Verstraete, 2005). MFCs have attracted interest due to their capacity to produce electricity ecologically and sustainably. Nevertheless, the reduced voltage output of MFC has become a noteworthy issue. As a result, many research endeavors have been undertaken to examine each element of MFC, particularly the substrate. Various substances, ranging from simple ones like glucose and acetate to more complicated ones like starch, sludge, cellulose waste, and sediments found in seas and rivers, can all be used as substrates in MFC (Lu et al., 2009; Rahimejad et al., 2011; Zhu et al., 2015; Nitorisavut & Regmi, 2017). Biomass substrates are becoming increasingly important because of their high lignocellulosic content, a great resource for nourishing bacteria in the MFC. These materials, used as substrates for energy generation and storage, are highly sought after because they are easy to get, quickly replenishable, and have minimum carbon dioxide emissions.

The coconut leaf, known for its high lignocellulosic content, plays a vital role in generating power in MFC. Our previous study has shown that using coconut waste as a substrate for MFCs resulted in the highest power density of $230 \mu\text{W}/\text{m}^2$, surpassing that of rice husk and bamboo waste (Ujai et al., 2023). It highlights the considerable potential of coconut-derived materials in improving MFC performance. The palm tree, scientifically named *Cocos nucifera* L., plays an essential role in the economy of many Pacific Islands, making a substantial contribution to their prosperity. The palm produces clusters of nuts monthly (Henrietta et al., 2022). Each nut consists of a kernel surrounded by a strong wooden shell and covered by a thick fibrous husk. The palm frond displays a sequence of

leaves organized along a petiole or a strong wooden midrib. The appropriateness of coconut leaves as a substrate for MFC arises from various crucial features. As a permanent crop, coconuts eliminate the need for frequent land preparation and additional work post-planting. Furthermore, the fact that coconut leaves are not limited to specific seasons guarantees their steady and constant availability every month. It makes coconut leaves an excellent and environmentally friendly option for MFC substrate material.

The complexities associated with the lignocellulosic composition pose challenges for bacteria, which potentially cause a decrease in the voltage generation by the MFC (Sahari et al., 2023). Additionally, the unpredictability of MFC electricity production must be considered. Therefore, developing a power management system specifically designed to tackle these challenges is of the utmost importance. A previous inquiry focused on a soil-based single-chamber Microbial Fuel Cell (SMFC) and integrating a DC-DC boost converter into the SMFC led to an extraordinary 150% increase in voltage (Sahari et al., 2022). Nevertheless, the voltage that was produced displayed a lack of stability. To tackle this issue, we put forth an innovative methodology that draws inspiration from Maximum Power Point Tracking (MPPT) systems implemented in solar energy systems. According to our hypothesis, the enhancement and stabilization of the voltage output of MFCs can be achieved by integrating a charge pump, DC-DC converter, and MPPT.

The present study utilized a substrate made of coconut leaf, an aluminum electrode, and a soil catalyst to construct the MFC. The power management system (PMS) integrated with the MFC comprised an MPPT, charge pump, and DC-DC converter. Two distinct dimensions of MFC compartments connected in the series were evaluated.

METHODOLOGY

Design Stage: Construction of Microbial Fuel Cell (MFC)

Preparation of MFC's electrode

This research employed aluminum foil electrodes measuring 7.35 cm in diameter, maintaining consistency across all MFC units. A small hole was created for wire insertion, which was then secured with solder. Subsequently, the electrode was inserted into a hole in the plastic container, with its connection secured using a hot glue gun to prevent water leakage. The electrode strip was pressed down to ensure maximum contact with the soil to enhance electron transfer rates. Figure 1 shows the visual depiction of the aluminum electrode strip.



Figure 1. Aluminum foil electrode



Figure 2. 700 ml and 350 ml MFC chambers

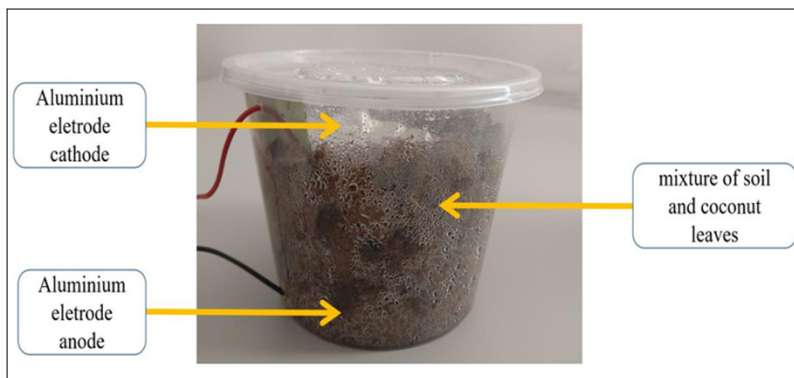

Figure 3. Arrangement of components for the MFC chamber

Construction of MFC Chamber

The small MFC units were assembled using 350 ml plastic containers for the chambers, as depicted in Figure 2, with a hole drilled on one side for accessibility. Two additional holes were made in the lower and upper sections for wire connections to the electrode strip. Soil was sourced from the backyard, while coconut palm leaves were obtained from the garden and shredded using garden shredders. A 5 g of shredded coconut palm leaves and 345 g of soil were mixed in the plastic container by hand or with a stick. Another MFC unit was prepared using 10 g of shredded coconut palm leaves and 695 g of soil for a larger unit, totaling six units. Subsequently, a thin layer of the soil mixture was poured, and the electrode was placed atop it. The container was then filled, and the electrode was positioned on top, as illustrated in Figure 3, detailing the MFC chamber's component arrangement.

Proposed Power Management System (PMS)

A charge pump, a DC-DC converter and the MPPT system were integrated into the PMS to establish a connection between the output and the MFC. Figure 4 depicts the block diagram that is proposed to represent this system. The block diagram depicts the MFC producing

an exceedingly low voltage, measuring around millivolts. As a result, the charge pump is connected to the MFC's output to extract a negligible amount of current from the MFC, thereby enabling the conversion of voltage magnitude and the subsequent charging of a capacitor or supercapacitor. The charged capacitor assists in activating the boost converter upon reaching the required voltage level, owing to the insufficient MFC voltage necessary for starting this basic electronic device. Hence, the incorporation of a charge pump into the PMS fulfills three fundamental objectives: (1) expedite the initiation of the boost converter; (2) extract power that is in closer proximity to the maximum achievable power of the MFCs through the consumption of low current from the MFCs; and (3) aid in the advancement of a power-efficient PMS. MPPT requires that the voltage from the charge pump be increased to a predetermined level by means of the DC-DC boost converter. MPPT becomes imperative in systems reliant on MFCs due to their nonlinear properties. MPPT techniques, often utilized in solar photovoltaic (PV) systems, play a vital role in monitoring and managing the energy transfer from the PV panel to the consumer's load. The details of the charge pump circuit and DC-DC boost converter are shown in Figures 5 and 6, respectively.

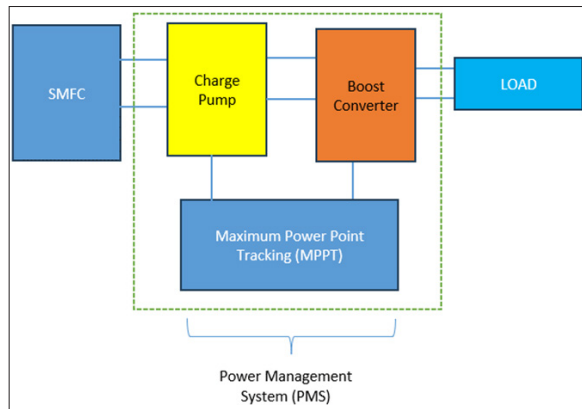

Figure 4. Proposed Block Diagram of Power Management System

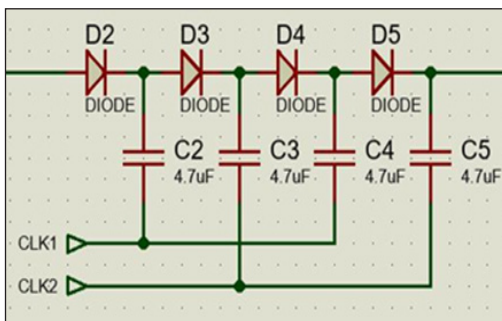

Figure 5. Design of Charge Pump

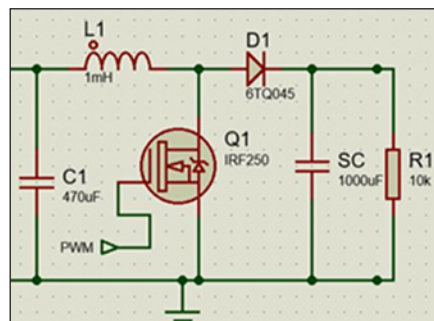

Figure 6. Design of DC-DC Boost Converter

Researchers globally incorporated various MPPT algorithms into their PMS configurations to track the Maximum Power Point (MPP) produced by the MFC. These existing MPPT algorithms include Perturb and Observe (P&O), Incremental Conductance (INC), Fuzzy Logic Control (FLC), Particle Swarm Optimization (PSO) and Model Predictive Control (MPC). In this study, the P&O MPPT algorithm is implemented, considering its simplicity and cost-effectiveness compared to other existing algorithms. The P&O algorithm operates by extracting the maximum allowable fuel cell power, where it periodically perturbs the duty cycle controlling the array and comparing the PV output power with that of the previous perturbation cycle, i.e., $I(i)$ is perturbed periodically until the change in its output power, $P(i)$ is equivalent to zero. The subsequent perturbation is made in the same direction if it leads to an increase; otherwise, it is made in the opposite direction (Eltamaly, 2018). Figure 7 shows the flowchart on the P&O algorithm operation.

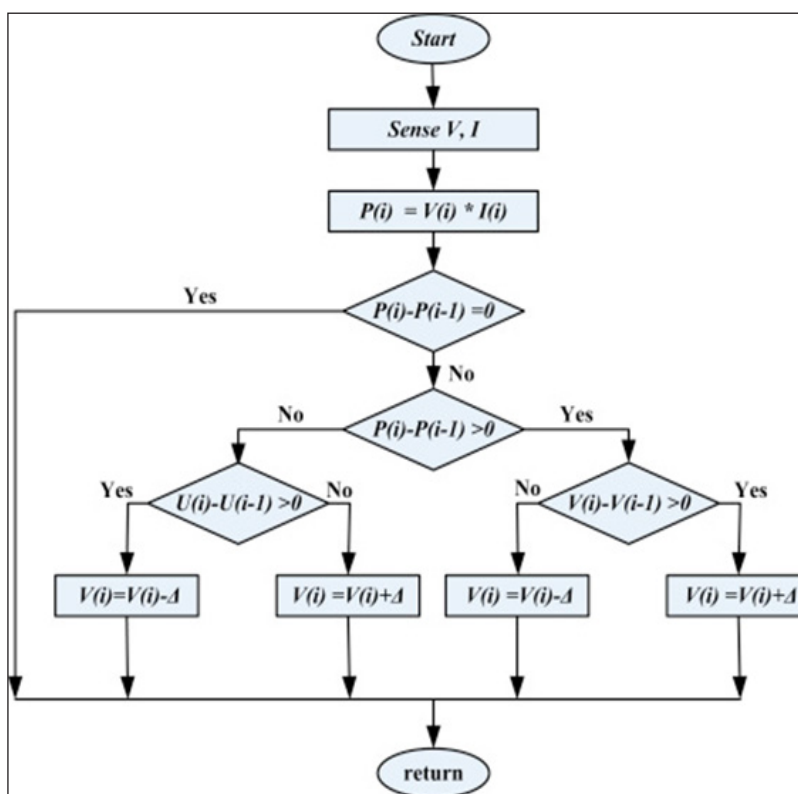

Figure 7. P&O algorithm flowchart (Eltamaly, 2018)

Electrical Measurement

A multimeter was used to measure voltage output from MFCs and compare the outcomes of smaller and larger MFC chambers.

RESULTS AND DISCUSSION

The Effect of Different Sizes of MFC Chambers on Voltage Production

This study examined the influence of chamber size variation on MFCs. Figure 8 demonstrates the voltage generation patterns in larger and smaller MFC chambers. The larger chamber showed almost little voltage for the first 6 days, in contrast to the smaller chamber of MFC. After 7 days of substrate fermentation, the voltage suddenly increased to 280mV, then remained stable at roughly 150mV from 9 to 12. On the other hand, the smaller chamber consistently showed greater voltages without a stable phase. Table 1 displays the average performance of both chamber sizes, showing that the smaller chamber produced around 50% more voltage than the bigger one. The difference in voltage production and stability between smaller and larger chambers in MFCs is influenced by several factors. Smaller chambers, with their higher surface area to volume ratio, enhance microorganism-electrode interactions, leading to higher voltage production (Fathima et al., 2024). Additionally, the confinement within smaller compartments increases microbial density, subsequently enhancing metabolic activity. Its heightened metabolic activity contributes to a higher voltage output by accelerating the rate of electron generation and transfer (Garimella et al., 2024). Moreover, in more compact chambers, the reduced distance that electrons and protons need to travel

Table 1
Average voltage of small chamber versus large chamber for 21 days

Size of Chamber	Voltage (mV)
Small chamber	212
Large chamber	164

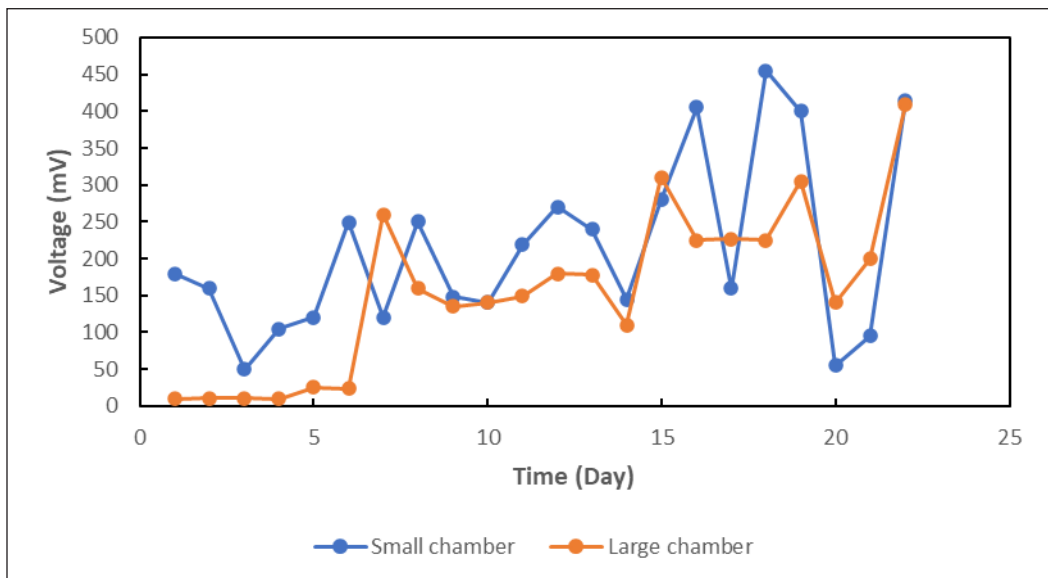

Figure 8. Voltage of small and large chambers of MFC

minimizes energy losses associated with diffusion, thereby increasing the efficiency of the electron transfer process and resulting in higher voltage output (Apollon, 2023). In contrast to the larger chambers, their lower surface area to volume ratio may produce lower voltage but offer greater stability due to their capacity to buffer against environmental fluctuations (Roy et al., 2023). Regardless of chamber size, voltage instability in both chamber types can be attributed to microbial activity and environmental conditions, such as nutrient availability, temperature, and pH, all of which influence the metabolic rates and electron transfer efficiency of microorganisms (Wani et al., 2022).-

The effect of different configurations of MFC chambers on Voltage Production

The configurations of MFC were compared without a Power Management System, specifically series versus parallel connections. The results indicate that the series configuration of MFC exhibits slightly higher voltage points compared to the parallel configuration, as in Figure 9. In the current study, we observed that in the series configuration, the voltage varied between 51 mV and 457 mV, while in contrast, in the parallel configuration, it spanned from 104 mV to 376 mV. Our findings indicate a notable disparity, suggesting that the series configuration consistently produces higher voltages compared to the parallel arrangement. Due to the additive effect of voltage, series MFCs have a higher voltage than parallel connections. The sum of the voltages of each MFC increases when MFCs are connected in series, leading to a greater overall voltage output. In parallel connections, however, the voltage across each MFC is constant; therefore, the sum of the currents determines the total current, not the voltage. As a result, series connections

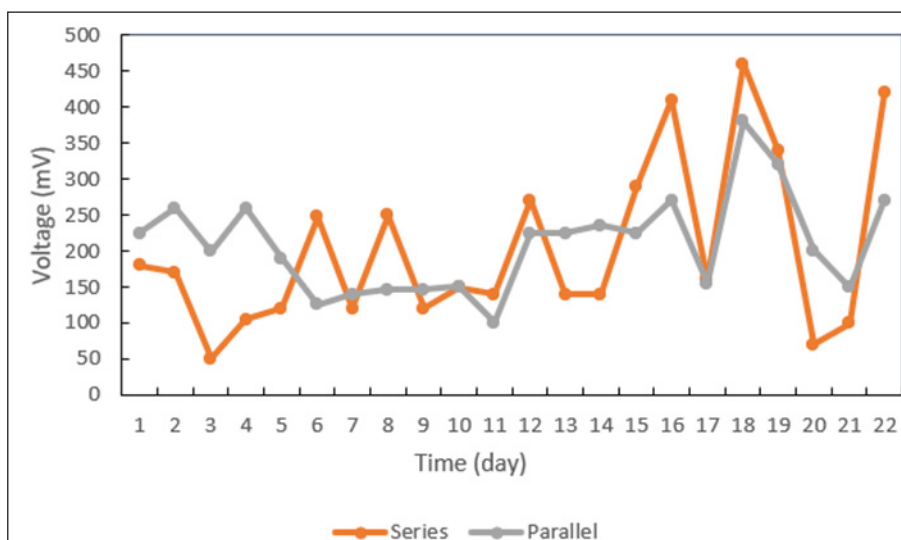

Figure 9 . Voltage from series and parallel configuration of MFC

exhibit greater efficacy in augmenting voltage output than parallel connections. The six chambers were connected in series to the power management system (Figure 10) to increase the voltage production. The voltage increased significantly by over 200% after integrating six series of MFCs connected with a charge pump, as illustrated in Table 2. Following the subsequent connection to a boost converter and MPPT, the voltage increased to 10.56 V, indicating a surge exceeding 500% compared to MFCs that were exclusively connected to a charge pump. The results of this study highlight the significant improvement in the performance of MFC that can be attributed to the effective integration of a charge pump, boost converter and MPPT into the PMS.

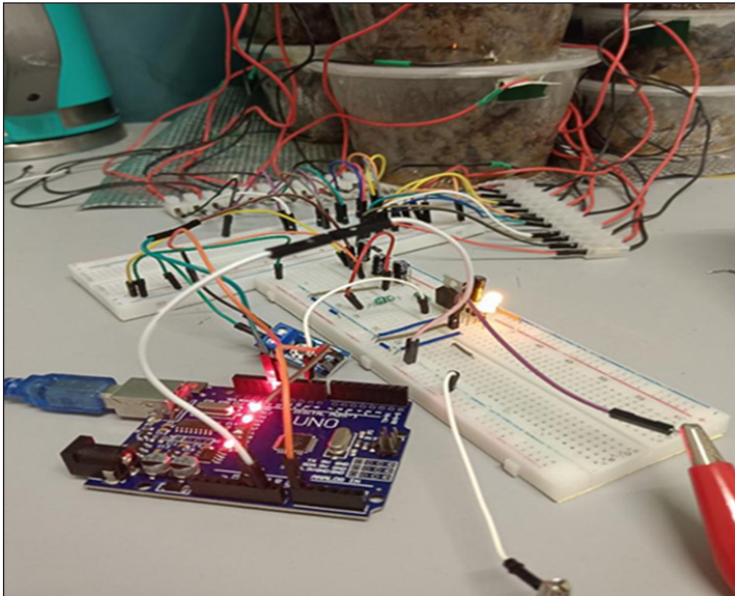

Figure 10. Series connection of 6 units MFC to the Power Management System (PMS)

Table 2
Comparison of electrical properties for different circuit configurations

Parameter	OVC 6 Series MFCs	OVC 6 Series MFCs + Charge Pump	OVC 6 Series MFCs + Charge Pump + Boost Converter + MPPT
Voltage (V)	0.134	2.5	10.56
Current (A)	0.216	0.015	0.036
Power (W)	0.028	0.125	0.038
Efficiency (%)	Initial value	94.64	98.73

We have conducted various experiments implementing different PMS approaches. Table 3 depicts the findings we obtained, illustrating the effect of implementing PMS on MFC.

The observed results indicate that the implementation of the DC-DC boost converter and charge pump with MPPT (Perturb and Observe algorithm) yielded a significantly higher and stable voltage, maintained consistently for 20 minutes.

Table 3
Comparison of voltages obtained from different PMS

Configuration	Voltage (V)	Power Density	Stability Time	Reference
Single-chamber MFC without PMS	-	230 μ W/m ²	N/A	Ujai et al., 2023
DC-DC boost converter without MPPT	1.722 (4 series of soil-based SMFC) 1.592 (4 series soil-based SMFC)	904 mW/m ² (graphite-activated carbon electrodes) 146 mW/m ² (copper-zinc electrodes)	N/A	Sahari et al., 2022
DC-DC boost converter, charge pump with MPPT (P&O algorithm)	10.56	-	20mins	*This study

Voltage Taken from Two Different Time Intervals and Room Conditions

The microbial fuel cell (MFC) voltages were measured at two specified times: from 7:00 to 8:00 in the morning and from 7:00 to 8:00 in the evening. The surroundings were dark in the morning, while it was brightly illuminated in the evening. Figure 11 illustrates a comparison of voltage levels observed during morning and evening measurements under

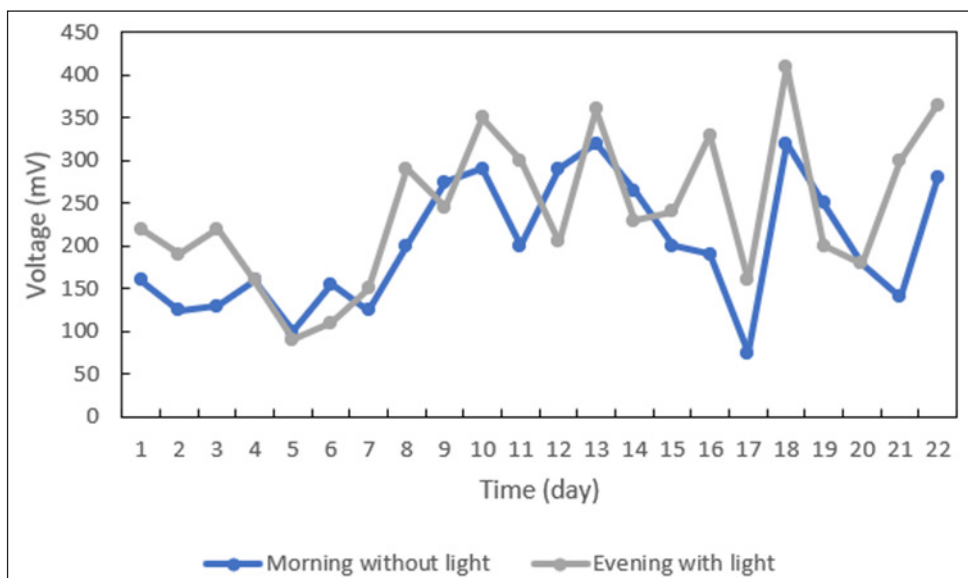

Figure 11. The voltage production from MFC at different room conditions

different room conditions. The microbial fuel cell (MFC) produces a higher voltage at night under bright conditions than in the morning when there is no light. The results indicate that the level of environmental brightness affects voltage generation in contrast to room temperature. This phenomenon could be explained by the photochemical alteration of organic substances caused by visible or ultraviolet light wavelengths, which have been proven to enhance bacterial proliferation in specific environments (Lindell et al., 1995).

COMPARISON OF PREVIOUS STUDIES

Table 4 illustrates the performance of various PMS configurations connected to the MFC. The results reveal that the voltage generated in this study aligns closely with values reported

Table 4
Comparison of MFC with PMS in the literature

Number of MFC	Type of MFC	Power Management System		Input Voltage (V)	Output Voltage (V)	Power (W)	Stability Time (minute)	Reference
		Circuit Topology	MPPT					
4	Single chamber	Boost converter	No	0.7	1.7	N/A	N/A	Sahari et al., 2022
2	Single chamber	Charge pump + boost converter	No	0.3	3.3	0.11	N/A	Umaz, 2020
1	Single chamber	Charge pump + boost converter	No	0.3	3.3	0.95	N/A	Meehan et al., 2011
1	Single chamber	Charge pump + transformer + boost converter	No	0.3-0.18	3.3	0.18	N/A	Zhang et al., 2012
1	Single chamber	MFC + charge pump + 2 boost converter	No	0.3	5	2.5	N/A	Donovan et al., 2011
1	Single chamber	MFC + charge pump + boost converter	Yes	0.3	3.3	N/A	3	Umaz, 2019
2	Single chamber	Charge pump	No	0.3	1.6-2.2	0.11	N/A	Carreon-Bautista et al., 2015
6	Single chamber	Charge pump	No	0.134	2.5	0.125	N/A	This study
6	Single chamber	Charge pump + boost converter + MPPT	Yes	0.134	10.56	0.038	20	This study

in previous literature. Moreover, our investigation demonstrates an enhancement in both voltage output and stability duration, reaching 20 minutes, attributable to the integration of MPPT within the PMS.

CONCLUSION

The study investigated how chamber size, MFC chamber configuration, and environmental factors affect MFC voltage. It was found that smaller MFC chambers yielded notably higher voltages than larger ones. Additionally, series connections resulted in higher voltages due to cumulative current effects. Interestingly, MFC brightness significantly influenced voltage, outweighing temperature effects. Furthermore, the study highlighted the crucial role of Maximum Power Point Tracking (MPPT) in Power Management System (PMS) setups. Integrating a charge pump, boost converter, and MPPT into a six-series PMS configuration significantly improved voltage output and stability. These findings underscore MPPT's effectiveness in optimizing MFC performance by ensuring consistent voltage output over time. The study provides compelling evidence supporting the integration of MPPT into MFC PMS for prolonged periods of reliable voltage production.

ACKNOWLEDGEMENT

A part of this work was supported by a Postgraduate Research Grant (UNI/F02/GRADUATES/86210/2024).

REFERENCES

- Apollon, W. (2023). An overview of microbial fuel cell technology for sustainable electricity production. *Membranes*, 13(11), Article 0884. <https://doi.org/10.3390/membranes13110884>
- Carreon-Bautista, S., Erbay, C., Han, A., & Sanchez-Sinencio, E. (2015). An inductorless DC–DC converter for an energy aware power management unit aimed at microbial fuel cell arrays. *IEEE Journal of Emerging and Selected Topics in Power Electronics*, 3(4), 1109–1121. <https://doi.org/10.1109/jestpe.2015.2398851>
- Chen, X. H., Tee, K., Elnahass, M., & Ahmed, R. (2023). Assessing the environmental impacts of renewable energy sources: A case study on air pollution and carbon emissions in China. *Journal of Environmental Management*, 345, Article 118525. <https://doi.org/10.1016/j.jenvman.2023.118525>
- Donovan, C., Dewan, A., Peng, H., Heo, D., & Beyenal, H. (2011). Power management system for a 2.5W remote sensor powered by a sediment microbial fuel cell. *Journal of Power Sources*, 196(3), 1171–1177. <https://doi.org/10.1016/j.jpowsour.2010.08.099>
- Eltamaly, A. M. (2018). Performance of MPPT techniques if photovoltaic systems under normal and partial shading conditions. In I. Yahyaoui (Ed.), *Advances in Renewable Energies and Power Technologies: Volume 1: Solar and Wind Energies* (pp. 115-161). Elsevier. <https://doi.org/10.1016/b978-0-12-812959-3.00004-6>

- Fathima, A., Ilankoon, I. M. S. K., Zhang, Y., & Chong, M. N. (2024). Scaling up of dual-chamber microbial electrochemical systems – An appraisal using systems design approach. *Science of The Total Environment*, 912, Article 169186. <https://doi.org/10.1016/j.scitotenv.2023.169186>.
- Garimella, S. S. S., Rachakonda, S. V., Pratapa, S. S., Mannem, G. D., & Mahidhara, G. (2024). From cells to power cells: Harnessing bacterial electron transport for microbial fuel cells (MFCs). *Annals of Microbiolgy*, 74, Article 19. <https://doi.org/10.1186/s13213-024-01761-y>
- Henrietta, H. M., Kalaiyarasi, K., & Raj, A. S. (2022). Coconut tree (*Cocos nucifera*) products: A review of global cultivation and its benefits. *Journal of Sustainability and Environmental Management*, 1(2), 257–264. <https://doi.org/10.3126/josem.v1i2.45377>
- Kabeyi, M. J., & Olanrewaju, O. A. (2022). Sustainable energy transition for renewable and low carbon grid electricity generation and supply. *Frontiers in Energy Research*, 9, Article 743114. <https://doi.org/10.3389/fenrg.2021.743114>
- Lindell, M. J., Granéli, W., & Tranvik, L. J. (1995). Enhanced bacterial growth in response to photochemical transformation of dissolved organic matter. *Limnology and Oceanography*, 40(1), 195–199. <https://doi.org/10.4319/lo.1995.40.1.0195>.
- Lu, N., Zhou, S., Zhuang, L., Zhang, J., & Ni, J. (2009). Electricity generation from starch processing wastewater using microbial fuel cell technology. *Biochemical Engineering Journal*, 43(3), 246–251. <https://doi.org/10.1016/j.bej.2008.10.005>
- Meehan, A., Gao, H., & Lewandowski, Z. (2011). Energy harvesting with microbial fuel cell and power management system. *IEEE Transactions on Power Electronics*, 26(1), 176–181. <https://doi.org/10.1109/tpel.2010.2054114>
- Nitorisavut, R., & Regmi, R. (2017). Plant Microbial Fuel Cells: A promising biosystems engineering. *Renewable and Sustainable Energy Reviews*, 76, 81–89. <https://doi.org/10.1016/j.rser.2017.03.064>
- Rabaey, K., & Verstraete, W. (2005). Microbial fuel cells: Novel biotechnology for energy generation. *Trends in Biotechnology*, 23(6), 291–298. <https://doi.org/10.1016/j.tibtech.2005.04.008>
- Rahimnejad, M., Najafpour, G. D., Ghoreyshi, A. A., Shakeri, M., & Zare, H. (2011). Methylene blue as electron promoters in microbial fuel cell. *International Journal of Hydrogen Energy*, 36(20), 13335–13341. <https://doi.org/10.1016/j.ijhydene.2011.07.059>
- Roy, H., Rahman, T. U., Tasnim, N., Arju, J., Rafid, M. M., Islam, M. R., Pervez, M. N., Cai, Y., Naddeo, V., & Islam, M. S. (2023). Microbial fuel cell construction features and application for sustainable wastewater treatment. *Membranes*, 13(5), Article 490. <https://doi.org/10.3390/membranes13050490>
- Sahari, S. K., Butit, A. M., Ngaini, Z., Arief, Y. Z., Kipli, K., Anyi, M., Awang, A., Muhammad Kashif, M. K., Mahmood, M. R., Embong, Z., Lilik Hasanah, L. H., Kram, A. R., & Sawawi, M. (2023). Bioelectricity generation from bamboo leaves waste in a double chambered microbial fuel cell. *Sains Malaysiana*, 52(6), 1855–1864. <https://doi.org/10.17576/jsm-2023-5206-20>
- Sahari, S. K., Rosli, M. Z. F., Butit, A. M., Kipli, K., Anyi, M., Awang, A., Sawawi, M., Mahmood, M. R., Hasanah, L., Kram, A. R., Embong, Z., & Nahrawi, H. (2022). Fabrication of single chamber microbial fuel cell (SMFC) using soil as a substrate. *Pertanika Journal of Science and Technology*, 30(2), 1103–1114. <https://doi.org/10.47836/pjst.30.2.14>

- Santoro, C., Arbizzani, C., Erable, B., & Ieropoulos, I. (2017). Microbial fuel cells: From fundamentals to applications. A Review. *Journal of Power Sources*, 356, 225–244. <https://doi.org/10.1016/j.jpowsour.2017.03.109>
- Ujai, N. U. M., Sahari, S. K., Sawawi, M., Kipli, K., Awang, A., Mahmood, M. R., Hasanah, L., Kram, A. R., & Ngaini, Z. (2023). The effect of nutrients in anodic chamber to the performance of microbial fuel cell (MFC). *Pertanika Journal of Science and Technology*, 32(1), 205–215. <https://doi.org/10.47836/pjst.32.1.12>
- Umaz, R. (2019). A two-stage power converter architecture with maximum power extraction for low-power energy sources. *Turkish Journal of Electrical Engineering & Computer Sciences*, 27(6), 4744–4755. <https://doi.org/10.3906/elk-1811-6>
- Umaz, R. (2020). A power management system for microbial fuel cells with 53.02% peak end-to-end efficiency. *IEEE Transactions on Circuits and Systems II: Express Briefs*, 67(11), 2592–2596. <https://doi.org/10.1109/tcsii.2019.2951810>
- Wani, A. K., Akhtar, N., Sher, F., Navarrete, A. A., & Américo-Pinheiro, J. H. P. (2022). Microbial adaptation to different environmental conditions: Molecular perspective of evolved genetic and cellular systems. *Archives of Microbiology*, 204(2), Article 144. <https://doi.org/10.1007/s00203-022-02757-5>
- Zhang, D., Yang, F., Shimotori, T., Wang, K. C., & Huang, Y. (2012). Performance evaluation of power management systems in microbial fuel cell-based energy harvesting applications for driving small electronic devices. *Journal of Power Sources*, 217, 65–71. <https://doi.org/10.1016/j.jpowsour.2012.06.013>
- Zhu, D., Wang, D. B., Song, T., Guo, T., Wei, P., Ouyang, P., & Xie, J. (2015). Enhancement of cellulose degradation in freshwater sediments by a sediment microbial fuel cell. *Biotechnology Letters*, 38(2), 271–277. <https://doi.org/10.1007/s10529-015-1985-z>